

CardioChek[®]

Printer



REF 2750

Designed exclusively for use with CardioChek[®] Plus and CardioChek[®] PA analyzers, versions 2.55 and greater.

Important Safety Instructions

Warning

1. Only use the AC adapter provided with this printer, or an AC adapter that has been approved for use with this printer. Use of an incorrect AC adapter may cause risk of overheating or fire.
2. Do not bend or place a heavy object on the power cord as it could damage the cord and result in risk of electric shock or fire. Do not use the power cord if damaged or frayed.
3. The thermal print head may become quite hot after printing. Be careful when changing labels and cleaning the thermal head.

Caution

1. Never insert objects of any kind into this printer as they may touch dangerous voltage points or short out parts, and may result in a risk of fire or electric shock. Never spill liquid of any kind on the printer.
2. This printer contains no user-serviceable parts. Do not attempt to service the printer yourself as this can expose you to dangerous voltage points or other risks. Repair service should be performed by a trained technician.
3. Do not use this printer near water or in extreme humidity.
4. Be sure to hold only the connector end of the power cord or interface cable when disconnecting. Repeated pulling on the cable could damage the cable.
5. If any of the following conditions occur, turn off the printer and unplug the power cord from the power outlet:
 - The power cord is damaged or frayed.
 - Liquid has been spilled into the printer or the printer has been exposed to rain or water.
 - The printer does not recover from an error or the printer does not operate normally when the operating instructions are followed.
 - The printer exhibits a distinct change in performance, such as emitting a strange noise, odor, or smoke.
6. Before using your printer, please remove the clear protective tape covering on the engine cover and roll cover.
7. When the printer is unused for a period of time without a label, the platen rubber may become stuck. This condition may cause a fatal error in the printer mechanism. To avoid this, please keep a label loaded in the printer — even when not in use.
8. Do not use the printer without closing the print engine cover.

Contents



CardioChek Printer



CardioChek
Printer Label Roll

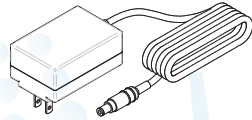

CardioChek Printer
Power Supply

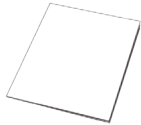

CardioChek
Printer
User Guide

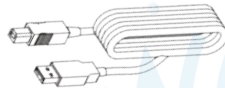

CardioChek Plus
USB Printer
Connection Cable

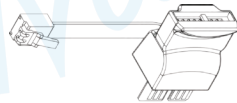

CardioChek PA Serial
Connection Cable
*(May also be used with
CardioChek Plus
analyzers.)*

Installation

For best performance, we recommend that you install your CardioChek printer on a flat surface in a location that satisfies the following environmental conditions:

- Not subject to vibration
- Not exposed to direct sunlight
- Dust-free
- Condensation-free
- Temperatures: 59 to 95°F (15 to 35°C)
- Humidity: 30% RH to 80% RH (non-condensing)

FCC Compliance Statement

This equipment has been tested and found to comply with the limits for a Class B digital device, pursuant to Part 15 of the FCC Rules. These limits are designed to provide reasonable protection against harmful interference in a residential installation. This equipment generates, uses and can radiate radio frequency energy and, if not installed and used in accordance with the instructions, may cause harmful interference to radio communications. However, there is no guarantee that interference will not occur in a particular installation. If this equipment does cause harmful interference to radio or television reception, which can be determined by turning the equipment off and on, the user is encouraged to try to correct the interference by one or more of the following measures:

- Reorient or relocate the receiving antenna.
- Increase the separation between the equipment and receiver.
- Connect the equipment into an outlet on a circuit different from that to which the receiver is connected.
- Consult the dealer or an experienced radio/TV technician for help.

Changes or modifications not expressly approved by PTS, Inc. could void the user's authority to operate the equipment.

Applicable EC Directives and Standards

Directive	Title
2004/108/EC	EC Electromagnetic Compatibility Directive
2006/95/EC	EC Low Voltage Directive
2009/125/EC	Directive on Eco-Design of Energy-related Products
2011/65/EU	Restriction of the use of certain hazardous substances (RoHS) Directive

Standards

EMC	EN55022 class B EN61000-3-2, EN61000-3-3 EN55024
LVD	EN60950-1
RoHS	EN50581

Technical Support and Ordering Labels and Parts

Contact PTS, Inc. at +1.877.870.5610 or visit us online at www.cardiochek.com.

REF 2750 CardioChek Printer

REF 2759 CardioChek Printer Power Supply

REF 2151 CardioChek Printer Label Roll

REF 2757 CardioChek Plus USB Printer Connection Cable

REF 2758 CardioChek PA Serial Connection Cable

(May also be used with CardioChek Plus analyzers)

Specifications

CardioChek Printer

The CardioChek printer is a compact printing device specifically designed for label printing with the CardioChek PA and CardioChek Plus analyzers.

Printer

Technology	Direct thermal
Resolution	300 dpi (11.81 dots/mm)
Max. Paper Width	2.28 in. (57.9 mm)
Max. Printable Width	1.92 in. (48.8 mm)
Print Speed	100 mm/sec max
Interface	650 USB
Operating voltage	DC11.4 V to DC 12.6 V
Current Consumption	2.8 A (Normal)
Current Consumption	3.0 A (Maximum)
Dimensions	4.48 in. (W) x 6.77 in. (D) x 5.83 in. (H) 113.8 mm (W) x 172.0 mm (D) x 148.0 mm (H)
Weight	Approx. 1.08 lbs. (490 g)
Life Span	15 km

Environment

Temperature	Operating:	41°F to 104°F (5°C to 40°C)
	Storage:	-4°F to 140°F (-20°C to 60°C)
Humidity	Operating:	30% RH to 80% RH (non-condensing)
	Storage:	30% RH to 90% RH (non-condensing)

Status Light Indicators

LED Indicator	State	LED Indicator	State
Off	Power off/Stand-by	Off	Power off/Stand-by
Steady Green	On-line	Blinking Yellow 2*	Buffer overflow
Steady Yellow	Off-line	Blinking Red 1*	Head temperature error
Blinking Green 1*	Paper out	Blinking Red 2*	Voltage error
Blinking Green 3*	Cooling down	Blinking Red 3*	Head error
Blinking Yellow 1*	Paper jam	Blinking Red 5*	Hard error

*The number refers to the number of blinks.



Caring For Your Printer

Your printer is a high-precision device that's designed for trouble-free operation. Just follow these few precautions:

Note: The printer is designed for use with CardioChek printer labels only. Use of improper labels may damage the printer and void your warranty.

- Do not operate the printer in a dusty environment.
- Keep the printer out of direct sunlight.
- Turn the printer off when not in use.
- Pull the power plug out when the printer is not in use for a long time.

A Word About Labels

For best results, we recommend the use of CardioChek printer labels. Other brands may not be engineered to provide optimum, trouble-free results with your printer; therefore, they may not work with your printer or they may damage it and void your warranty.

The printer labels have a sensor mark on the backing of each label for top-of-label alignment. Check to be sure the labels have this mark before loading them into the printer.

Caring For Labels

The labels are sensitive to heat, moisture, and light. With this in mind:

- Store labels in a cool, dry place.
- Do not scratch or rub labels with a hard object.
- Do not expose labels to high heat or direct light for an extended period of time.
- Keep organic solvents away from labels.

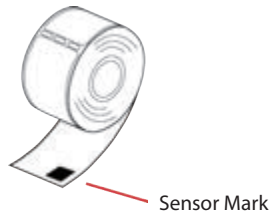

How to Set Up the CardioChek Analyzers for Printing

CardioChek PA Analyzer

1. If the analyzer is off, press either button to turn on the analyzer. Wait for the display to read INSTALL MEMO CHIP or INSERT STRIP.
Note: If RUN TEST is displayed, go to Step 3.
2. Ensure both power supply and communication cables are connected.
3. Press Next. The display will read RUN TEST.
4. Press Next until USER SET is displayed.
5. Press Enter. PRINT is displayed.
6. Press Enter. MEDIA is displayed.
7. Press Enter, or Next then Enter to select L (LABEL) and return to P (PAPER) MEDIA.
8. Press Next, then press Enter to display COPIES.
9. Press Next to display 01, 02, or 03 copies.
10. Press Enter to accept the desired number of copies and return to COPIES.
11. Press Next, then press Enter to display OUTPUT.
12. Press Next until PRINT A is displayed.
13. Press Enter to select and return to OUTPUT.
14. Press Next. TEST is displayed.
15. Press Enter for a sample printout.

Removing Stuck Labels

If a label becomes stuck in your printer, remove it as follows:

1. Make sure that the printer is turned off. If the Status Light is on, hold the Power Button until the printer is turned off.
2. Swivel the Roll Cover open. With a pair of scissors, cut the label stock between the label roll and the paper inlet slot.
3. Remove the Print Engine Cover by pulling it toward you while pressing the left and right side of the Print Engine Cover.
4. Release the pressure on the label stock by moving the Platen Release Lever forward. When you let go of the Platen Release Lever, it goes back to the original position. Hold the Platen Release Lever until a label is removed.
5. Remove the stuck label.



CAUTION: DO NOT touch print engine. It may be hot.

6. Return the Platen Release Lever to the original position.
7. Replace the Print Engine Cover, starting at the bottom, and push the top edge forward until the Print Engine Cover snaps into place.

Adjusting the Position of Labels

If you find the labels are advancing at an angle, follow these steps to realign them:

1. Swivel the label cover open and remove the print engine cover by pulling forward on the edges at the top of the cover.
2. Release the pressure on the label stock by moving the platen release lever forward. When you let go of the platen release lever, it goes back to the original position. Hold the platen release lever until the adjustment of the label position completes.

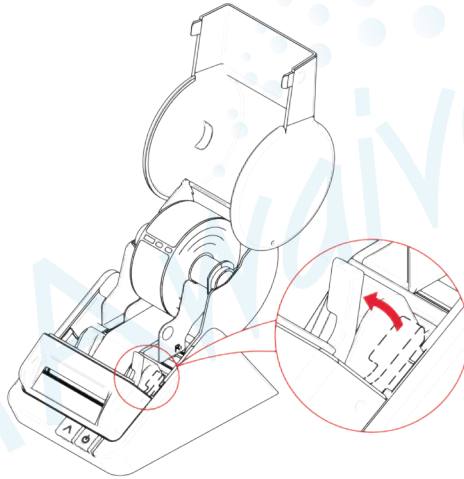

3. Realign the label stock so it is straight.
4. Return the platen release lever.
5. Make sure the labels feed through the paper inlet slot.
6. Replace the print engine cover, starting at the bottom, and push the top edge forward until the cover snaps into place.

How to Set Up the CardioChek Analyzers for Printing, cont'd.

CardioChek Plus Analyzer

1. If the analyzer is off, press either button to turn on the analyzer. Wait for the display to read INSTALL MEMO CHIP or INSERT STRIP.
Note: If RUN TEST is displayed, go to Step 3.
2. Ensure both power supply and communication cables are connected.
3. Press Next. The display will read RUN TEST.
4. Press Next until SETTINGS is displayed.
5. Press Enter, then Next until PRINT is displayed.
6. Press Enter. PRINT MEDIA is displayed.
7. Press Enter. The paper icon and the label icon will display.
8. Press Enter to select the highlighted icon or press Next to highlight the desired print media.
9. Press Enter to accept and return to PRINT MEDIA.
10. Press Next, then press Enter to display PRINT COPIES.
11. Press Enter to select the highlighted icon or press Next to highlight one, two, or three copies.
12. Press Enter to accept and return to PRINT COPIES.
13. Press Next, then press Enter to display OUTPUT SELECT.
14. Press Enter to select the highlighted printer icon or press Next to highlight the PC icon.
15. Press Enter to accept and return to OUTPUT SELECT.
16. Press Next. TEST PRINTER is displayed. Press Enter for a sample printout.

How to Print Results from Memory

(CardioChek PA & CardioChek Plus analyzers)

1. If the analyzer is off, press either button to turn on the analyzer. Wait for the display to read INSTALL MEMO CHIP or INSERT STRIP.
Note: If RUN TEST is displayed, go to Step 3.
2. Ensure both power supply and communication cables are connected.
3. Press Next. The display will read RUN TEST.
4. Press Next until MEMORY is displayed, then press Enter.
5. Press Enter to select CHEM or press Next, then Enter to select CONTROL.
6. Press Next to highlight the test name, then press Enter to select. (LIPIDS for example)
7. Press Next to highlight the date/time of the test result you want to print.
8. Press Enter to print the selected results.

Loading a Roll of Labels

Prepare the roll of labels

1. Remove the sticker from the beginning of the roll of labels.

Note: Make sure there is a black sensor mark on the label backing.

2. If needed, cut between the labels to create a "leader."
3. If the end of the roll is not prepared as shown above, cut between the labels leaving as much backing as possible.



Load the roll of labels

WARNING: DO NOT THROW SPINDLE AWAY WHEN CHANGING LABEL ROLLS

1. Make sure the power cord is connected and the printer is turned on. The green status light should be flashing.
2. Press the left and right side of the label cover and lift up the edge of the label cover to open.
3. Remove the spindle from the printer and insert the label roll on the spindle.
4. Insert the labels and spindle into the printer. If necessary, adjust the guides to fit the labels as shown below.
5. Insert the free end of the label roll, label side down, into the paper inlet slot. Push the label stock into the paper inlet slot until you feel a slight resistance. Continue pushing gently. The printer automatically feeds the labels through and aligns the end in the exit slot.

If the label end doesn't appear through the slot:

Press and release the form feed button to advance the labels. 

6. Close the label cover.

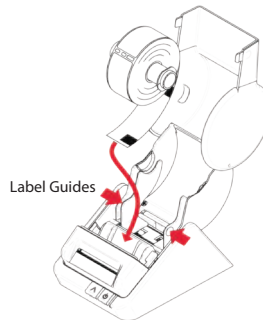
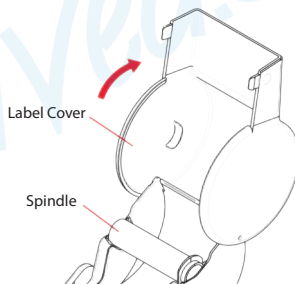

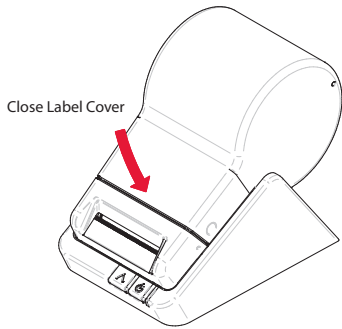

Changing a Label Roll

WARNING: DO NOT THROW SPINDLE AWAY WHEN CHANGING LABEL ROLLS

This procedure describes how to remove and replace label rolls.

- When you run out of labels, the green status light on the front of the printer flashes.

Removing the Old Roll



CAUTION: DO NOT pull on the labels to remove them from the printer. This may cause labels to get stuck inside the printer.

1. Tear off any printed labels. If labels aren't torn off, they may get jammed when you perform step 2.
2. Press and hold the form feed button.  The labels will reverse out of the printer. If this does not work, see "Adjusting the Position of Labels" to release the platen to remove the labels.

DISTRIBUTED BY:

CLIA*waived*TM Inc.

11578 Sorrento Valley Rd., Ste. 26 | San Diego, CA 92121 | 858.481.5031 | cliawaived.com



Manufacturer of the
CardioChek System

Polymer Technology Systems, Inc.

7736 Zionville Road, Indianapolis, IN 46268 USA
Office: +1 (317) 870.5610 Fax: +1 (317) 870.5608
Toll-Free in the U.S.: +1 (877) 870.5610

CardioChek®, PTS Parseq®, and NEMO Cypher® are
registered trademarks of Polymer Technology Systems, Inc.
PS-004527 Rev. 0 08/13



CardioChek.com